

## EMM-3U Universal Electronic MiniZone™ Panel

### PRODUCT DATA



### APPLICATION

The EMM-3U Universal Electronic MiniZone™ Panel controls single-stage, multi-stage, conventional or heat pump heat/cool equipment and is used on two- and three-zone applications.

### FEATURES

- Compatible with single-stage, multi-stage, conventional or heat pump applications.
- Uses virtually any Honeywell four-wire, single-stage, multi-stage, or Trol-A-Temp heat pump thermostat.
- Optional Discharge Air Temperature Sensor for capacity control with adjustable high and low limits.
- System and Zone LEDs indicate system status.
- Automatic zone changeover with 20-minute changeover timer.
- Individual zone fan control.
- Thermal circuit breaker protects panel and transformer from damage if miswired.
- Purge timer protects equipment between calls for heating and cooling.
- Uses spring-open/power-closed, spring-closed/power-open, and power-open/power-closed dampers.
- Single or dual transformer equipment compatible.

For Internet access:

[www.honeywellzoning.com](http://www.honeywellzoning.com)

For technical support, call 1-800-828-8367.

To download Zoning literature: <http://hbctechlit.honeywell.com>

### Contents

Application .....	1
Features .....	1
Specifications .....	2
Ordering Information .....	2
Installation .....	4
Troubleshooting .....	15



## SPECIFICATIONS

### Input Ratings:

Voltage: 20 - 30 Vac, 50/60 Hz.  
Power: 10.75 VA nominal.

### Output Ratings:

Equipment Relays and Zone Relays:  
1.5A run, 3.5A inrush, 200,000 cycles (30 Vac).  
1.5A run, 7.5A inrush, 100,000 cycles (30 Vac).

**Humidity Ratings:** 5% to 90% RH non-condensing.

### Temperature Ratings:

Shipping: -20° to 120°F.  
Operating: -40° to 150°F.

### LED:

SYSTEM mode LED (5) used to communicate equipment status:

- Red Heat: Heat mode.
- Green Cool: Cool mode.
- Yellow Purge: Purge mode.
- Green Fan: Fan mode.
- Red EM Heat: Emergency Heat mode.
- Flashing Red Heat: System exceeds high DATS input.
- Flashing Green Cool: System exceeds low DATS input.
- Flashing Yellow Purge: No DATS or DATS failure.
- Off: Idle mode.

ZONE LED (3) used to communicate damper status:

- Green: Dampers are opening or open.
- No Color: Dampers are closing or closed.

### Finish:

Taupe cover.  
Gray base.

**Dimensions:** See Fig. 1.

**Mounting:** Mounts with four one-inch no. 8 screws (provided) through holes in cabinet. Wall anchors provided.

**Wiring:** 18 to 22 gauge wire for all equipment and system connections.

### Wiring Connections:

Thermostat: R-C-E-W1-Y1-G-W2-Y2-O-B-L.  
Dampers: M6 (Closed); M4 (Open); M1 (Common).  
Discharge Air Temperature Sensor: DATS-DATS.  
Transformer: R-C.  
Equipment: RC-RH-W1-W2-E-B-O-Y1-Y2-G.

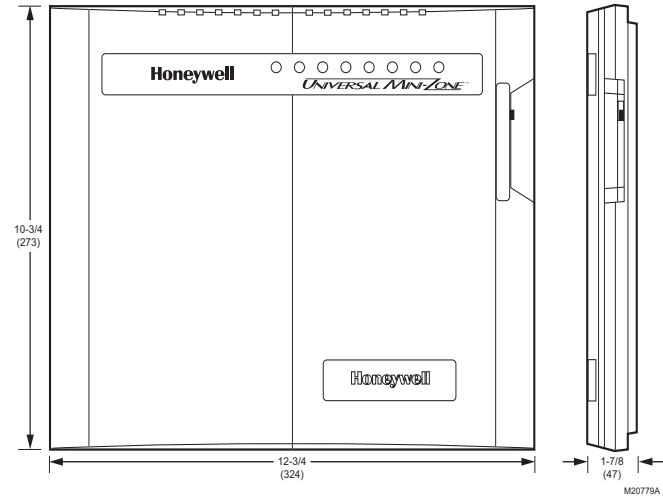

**Fig. 1. EMM-3U dimensions in in. (mm).**

### Approvals:

Federal Communications Commission: Class B.  
NEMA DC-3: Not required.

### Thermostats (See Table 1):

Most conventional four-wire (R, W, Y, G) thermostats can be used to control conventional, heat pump, or multi-stage equipment.  
Manual or automatic changeover switching thermostats can be used.  
Multi-stage or select heat pump thermostats can also be used.

## ORDERING INFORMATION

When purchasing replacement and modernization products from your TRADELINE® wholesaler or distributor, refer to the TRADELINE® Catalog or price sheets for complete ordering number.

If you have additional questions, need further information, or would like to comment on our products or services, please write or phone (1-800-468-1502):

1. Your local Automation and Control Solutions Sales Office (check white pages of your phone directory).
2. Honeywell Automation and Control Solutions Customer Care  
1985 Douglas Drive North  
Golden Valley, MN 55422

In Canada—Honeywell Limited/Honeywell Limitée, 35 Dynamic Drive, Scarborough, Ontario M1V 4Z9.  
International Sales and Service Offices in all principal cities of the world. Manufacturing in Australia, Canada, Finland, France, Germany, Japan, Mexico, Netherlands, Spain, Taiwan, United Kingdom, U.S.A.

**Table 1. Recommended Thermostats.**

System	Non-Programmable	Programmable
Single-Stage	T87F1859/Q539A1014 T87F4010/Q539A4026 T8501D1046 T8400C1016 T8400C1040 T8400C1099 T8501D1111	T8601D2027 T8600D2069 T8600D2028 T8601D2019 T8602D2018 T8602D2000 T8000C1002 T8000C1010 T8001C1019 PC8900/W8900A,C
Heat Pump <sup>b</sup>	Y594R1243 <sup>a,c,d</sup> Y594G1252 <sup>a,e</sup> T8411R1002 T8411R1028	T8611G2051 <sup>a</sup> T8011R1006 T8011R1014 T8011F1002
Multi-Stage <sup>b</sup>	T8424D1008 T8424D1016 T8524D1007 T8524D1015 Y594D1347 <sup>f</sup> T8524D1015	T8624D2004 T8624D2012 T8024D1002 T8024D1010 T8024F1007

<sup>a</sup>Heat pump thermostat with single Y first-stage terminals. See Heat Pump Thermostats section and Fig. 6.

<sup>b</sup>Multi-stage and heat pump thermostats are not required to control multi-stage and heat pump systems. They are used only when second stage or emergency heat control from the zone thermostat is needed.

<sup>c</sup>The Y594R1243 must be wired to the panel using the B terminal for changeover.

<sup>d</sup>Cut thermostat second-stage variable heating anticipator wire (gray).

<sup>e</sup>Cut thermostat first-stage fixed heating anticipator wire (bare) and second-stage variable heating anticipator wire (gray).

<sup>f</sup>Cut thermostat second-stage cooling anticipator wire (lowest bare wire).

**Recommended Dampers (See Table 2):**

Five ZD or ARD dampers maximum connected to each panel and a maximum of five dampers per zone.

Use SDCR for additional dampers required on one zone.

Dampers are connected to M1 Common, M4 Open, and M6 Closed (see Fig. 8-12 for hookups).

**Table 2. Recommended Dampers.**

Honeywell Damper Type	Round	Rectangular
Power-open/power closed (for systems >2000 cfm)	MARD	D642 using ML6161 Motor Actuator
Spring-open/power-closed (for systems <= 2000 cfm)	ARD	ZD

**Damper Connections:**

Motor Terminal	Damper Action
Common/M1	Common
Open/M4	Power Open
Closed/M6	Power Close

**Accessories:** For required accessories, see Table 3.

**Table 3. Required Accessories.**

Accessory	Description	
40 VA transformer	AT140D1046	
Capacity protector	C7735A1000	
Round static pressure regulator damper	7 SPRD	300 cfm
	8 SPRD	400 cfm
	9 SPRD	600 cfm
	10 SPRD	750 cfm
	12 SPRD	1200 cfm
	14 SPRD	1800 cfm
Rectangular static pressure regulator damper	16 SPRD	2400 cfm
	12 x 8 SPRD	1000 cfm
	12 x 10 SPRD	1200 cfm
	12 x 12 SPRD	1400 cfm
	20 x 8 SPRD	1600 cfm
	20 x 10 SPRD	2000 cfm
	20 x 12 SPRD	3000 cfm

## INSTALLATION

### Mounting

#### CAUTION

**Equipment Damage Hazard.**  
Do not mount EMM-3U inside HVAC equipment.  
Mount only on wall or on cold air return.

1. Mount the thermostats in each zone of the living space using the installation instructions provided with each thermostat.
2. Mount the dampers in the ductwork using the installation instructions provided with each damper.
3. Mount the EMM-3U zone panel near the HVAC equipment; locate it on a wall or on the cold-air return. See Fig. 2.
4. Level the EMM-3U for appearance only.

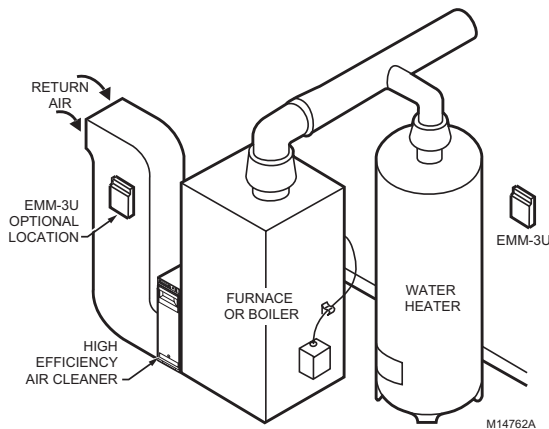

Fig. 2. EMM-3U mounting location.

### WIRING

#### CAUTION

**Voltage Hazard.**  
Can cause electrical shock or equipment damage.  
Disconnect power before continuing installation.

Wiring must comply with applicable codes, ordinances and regulations.

1. Connect thermostats as shown in Fig. 3-7.
2. Connect dampers as shown in Fig. 8-12.
3. Connect C7735A1000 Discharge Air Temperature Sensor (DATS) to the DATS terminals. The wires are not polarized; see Fig. 13.
4. Connect the HVAC equipment to the EQUIP terminals on the panel; see Fig. 13-18.
5. Connect a 40 VA, 24 Vac transformer to R (hot) and C (common). This must be a dedicated transformer. See Fig. 13.

### Thermostat Wiring

#### Conventional Equipment

Conventional (RWYG) thermostats can be used to control conventional, multi-stage and heat pump equipment. When single-stage thermostats are used, stages are engaged through the on-board 5 - 60 minute timer. If the equipment is a heat pump, the EMM-3U panel controls the reversing valve. If the thermostat has a common terminal, it is wired to C on the panel, see Fig. 3. Multi-stage conventional (non-heat pump) thermostats are wired with the second stage of heat and cool on the thermostat to W2 and Y2 on the panel. Leave the O/B thermostat jumper on the EMM-3U disconnected.

The PC8900 can be used as a zone thermostat. See Fig. 4 for hookup. The PC8900 with the W8900A or C controls up to 2 heat and 2 cool stages of conventional equipment. The PC8900 with the W8900A also controls heat pump equipment.

Connect a jumper on the W8900 from Rc to Rh as shown. Wire terminals R and C to a transformer. Alternately, if the zone control system current draw is within specifications, the R and C on the W8900 could be connected to R and C on the EMM-3U. The PC8900/W8900 draws 5 VA.

#### Heat Pump Equipment

Select a heat pump thermostat from Table 1. If the thermostat selected has a separate Y1 and W1 wire, connect as shown in Fig. 5, leaving the zone O/B thermostat type jumper on the EMM-3U disconnected

If the PC8900/W8900A is used, wire as shown in Fig. 4. This hookup engages second stage heat based on thermostat demand, but the Em Heat switch on the panel must be used to switch the panel to emergency heat.

NOTE: The thermostat Em Heat switch does not switch the panel to emergency heat.

If the thermostat selected from Table 1 has a single Y terminal for first stage heat and cool, wire as shown in Fig. 6 and 7. Wire either O or B (not both) from the thermostat to the O/B terminal on the EMM-3U. Locate the O/B thermostat jumper on the EMM-3U near each zone thermostat wiring terminal. Connect the jumper if O is used or leave the jumper disconnected if B is used. Connect second stage, auxiliary heat, to W2.

Conventional single stage thermostats can be used to control a heat pump if wired as shown in Fig. 3. In this case, the panel operates the reversing valve, the second stage is brought on by the panel stage timer, and emergency heat is activated by the EM heat switch on the panel. Leave the O/B thermostat type jumper disconnected when using conventional thermostats.

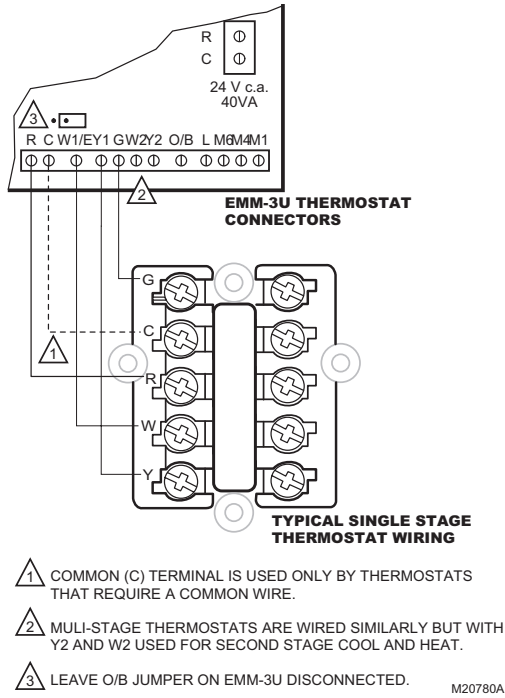

Fig. 3. Typical conventional thermostat wiring.

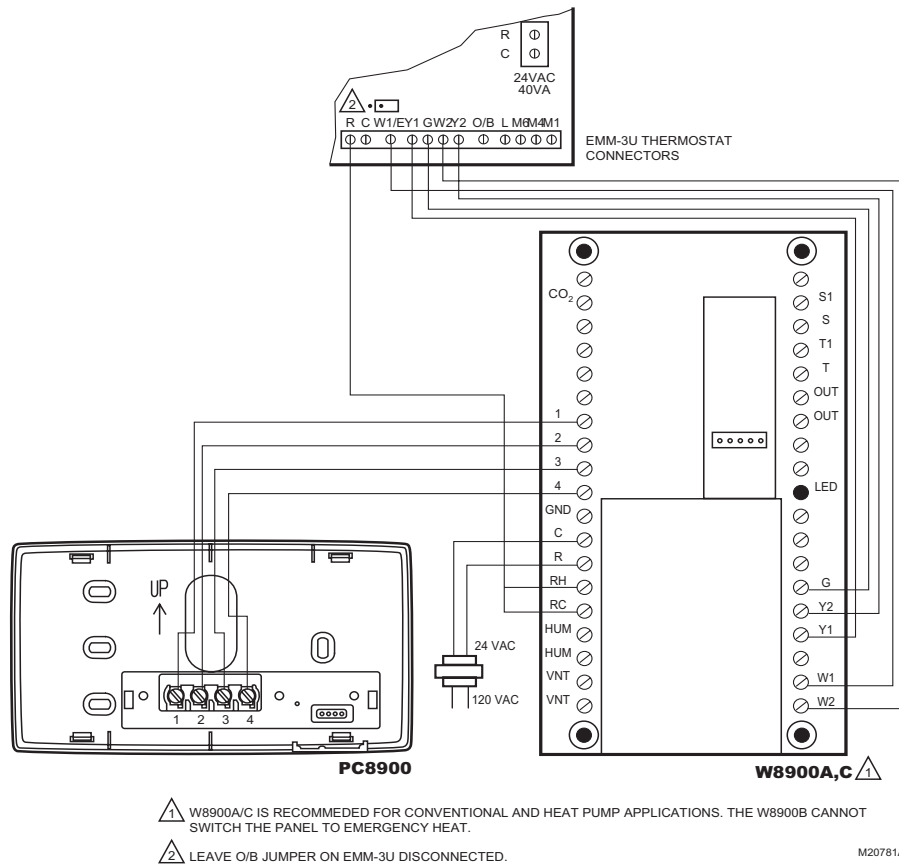

Fig. 4. PC89800 with W8900A,C Thermostat wiring.

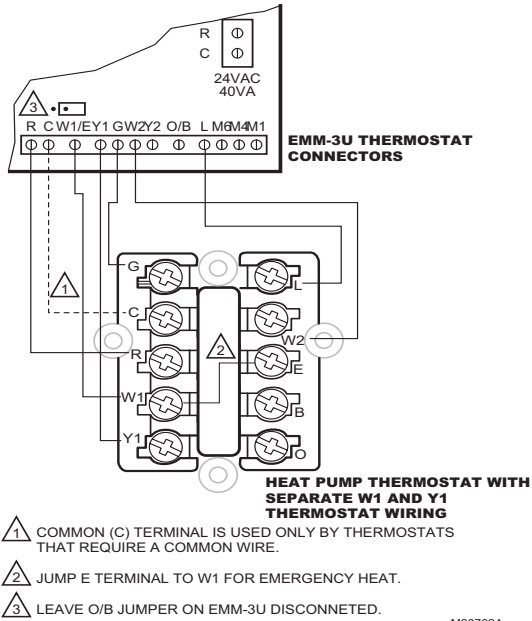

Fig. 5. Heat pump thermostat with separate W1 and Y1 terminal wiring.

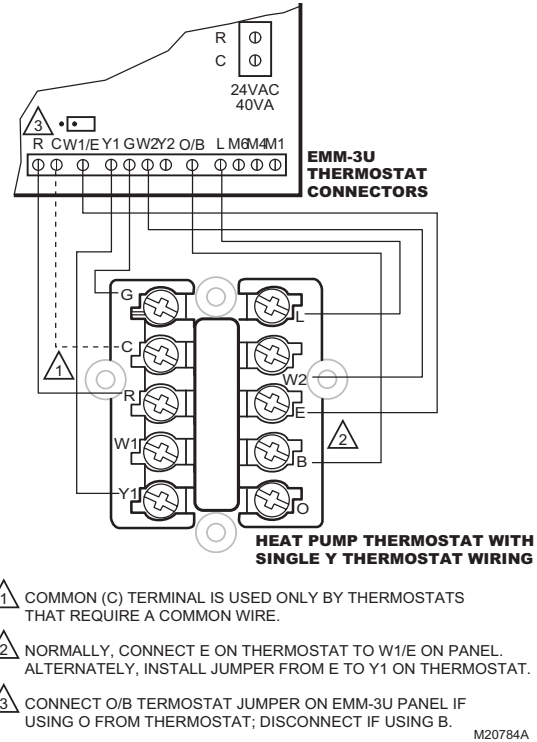

Fig. 7. Heat pump thermostat with single Y1 using B for changeover thermostat wiring.

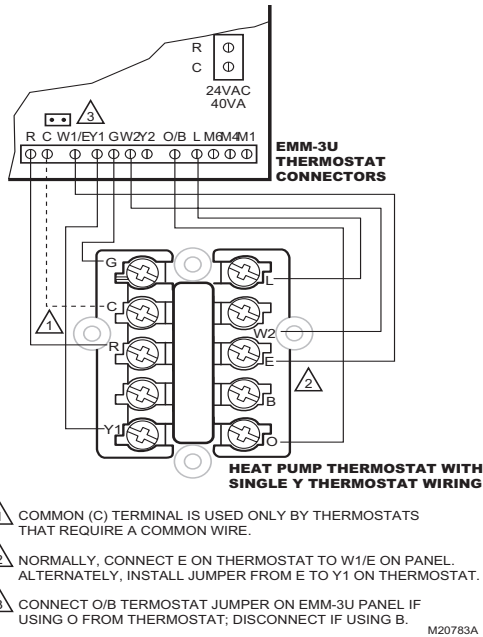

Fig. 6. Heat pump thermostat with single Y1 using O for changeover thermostat wiring.

## Damper Wiring

### ARD or ZD Dampers

Wire the ARD or ZD damper to the panel as shown in Fig. 8. Multiple dampers can be wired in parallel. Use these dampers on systems up to 2000 cfm.

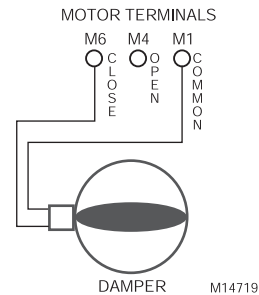

Fig. 8. Wiring ARD or ZD Damper to panel.

### AOBD Dampers

Wire the AOBD dampers to the panel as shown in Fig. 9. Two AOBD can be wired in tandem as shown in Fig. 10. More than two AOBD dampers require the Slave Damper Control Relay (SDCR).

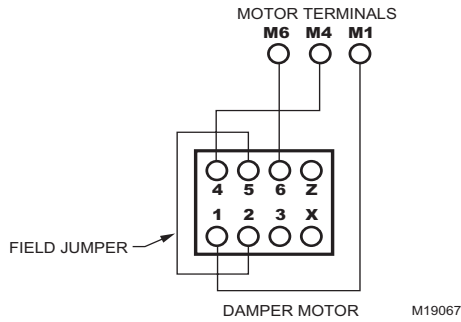

Fig. 9. Wiring AOBD Damper to panel.

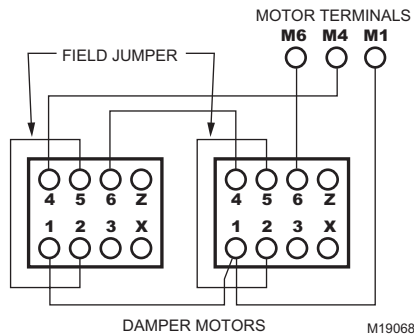

Fig. 10. Wiring two AOBD dampers in parallel.

### MARD Dampers or Dampers Using ML6161 Motor Actuator

Wire the MARD Damper or ML6161 Actuator to the panel as shown in Fig. 11. These are floating control actuators, but are controlled as two-position devices on the EMM-3U Panel. Multiple dampers can be wired in tandem.

The ML6161 Motor causes the damper LED to illuminate green constantly. Wire a relay as shown in Fig. 12 to restore damper position indication.

Use the MARD or D642 Damper with the ML6161 on systems 2000 cfm and higher.

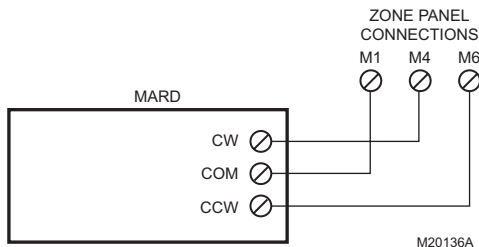

Fig. 11. Wiring MARD Damper or ML6161 Actuator to panel.

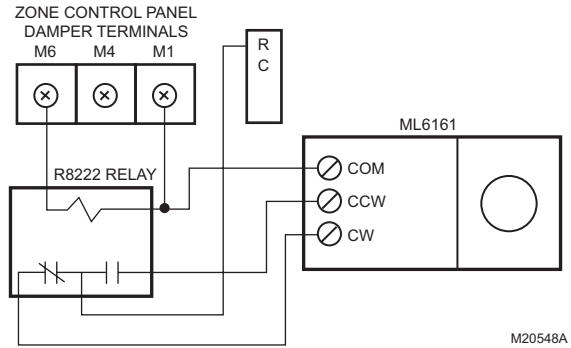

Fig. 12. MARD or ML6161 Damper Motor Actuator using R8222 Relay wiring.

### Discharge Air Sensor Wiring

Wire the C7735 Discharge Air Temperature Sensor (DATS) to the panel as shown in Fig. 13 -16.

The Purge LED (amber) flashes in all modes except purge if:

1. No DATS is connected to the EMM-3U.
2. There is a problem with the DATS sensor.
3. There is a problem with the DATS wiring.

The zone control panel will continue to operate correctly when the purge LED is flashing but without the high and low limit protection.

### Equipment Wiring

#### Conventional Equipment

Wire the heating and cooling equipment to the equipment terminals on the EMM-3U Panel as shown in Fig. 17.

Conventional Equipment: Leave DIP switch 4 set to On.

Electric Furnace: Set DIP switch 7 to Off to energize the fan with a call for heat.

Oil Heat: Wire the oil primary T, T terminals to the Rh and W equipment terminals. (If the oil primary has powered terminals, remove the Rh and Rc jumper.) See Fig 15 and 16.

Multi-Stage: Wire the equipment as shown in Fig. 13 using the W2 for second stage heating, and the Y2 for second stage cooling.

See the Operation section for stage configuration and other settings.

## Hot Water Heat Systems

### Hydronic Heat

Hydronic heat systems using zone valves or circulator relays for heating and dampers for cooling can be controlled by the panel. In this hookup, one thermostat is used per zone to control both heating and cooling. Use thermostats with separate Rc and Rh terminals to isolate the heating and cooling circuits. Connect the thermostat Rh and W to the zone valve and the Rc, Y and G to the zone control panel. Wire the thermostats and air conditioning equipment the same as for conventional equipment; see Fig. 3 and 16.

### Hydro Heat

Hydro heat systems using a boiler and hot water coil can be used with this zone control panel. Wire the zone valve or circulator relay to equipment terminals Rh and W. The Rc and Rh jumpers located above the equipment terminals must be removed if a separate transformer powers the heating and cooling circuits. Wire the cooling equipment, thermostats, and dampers the same as for conventional equipment; see Figure 19. Set DIP switch 7 to off if it is necessary for the fan to be energized on a call for heat. Alternatively, an Aquastat can be used to engage the blower based on water temperature.

### Heat Pump Equipment

See Fig. 17 and 18 for heat pump equipment wiring. Refer to the manufacturer instructions for additional wiring details and substitute the EMM-3U equipment terminals for the thermostat terminals shown.

If the same heat source is used for auxiliary heat and emergency heat:

- Connect the auxiliary heat to W2.

- Wire a jumper from W2 to E.
- Set DIP switch 12 to Off.

If auxiliary heat is separate from emergency heat:

- Connect the auxiliary heat to W2.
- Connect the emergency heat to E.
- Leave DIP switch 12 set to On.

Connect the changeover relay to the O or B equipment terminal (O is energized when the panel is in the cool mode, B is energized when the panel is in the heat mode).

### **IMPORTANT**

*Some heat pump manufacturers (such as York and Trane) use the B terminal as the transformer common. Do not connect the common from the equipment to the zone control panel.*

Connect the compressor wire to the Y1 terminal. If there is a 2<sup>nd</sup> stage compressor, wire it to Y2 with a jumper to W2.

To control a two-stage heat pump with auxiliary heat, select the TZ-4 TotalZone Zone Control panel.

Set DIP switch 4 to Off for heat pump operation, and set DIP switch 7 to Off for fan on a call for heat.

See the Operation section for additional configuration settings.

### Transformer

Wire a dedicated transformer to the R (hot) and C (common) terminals on the zone control panel as shown in Fig.13. One 40 VA, 24 Vac transformer powers up to five ARD or ZD Dampers and the panel.



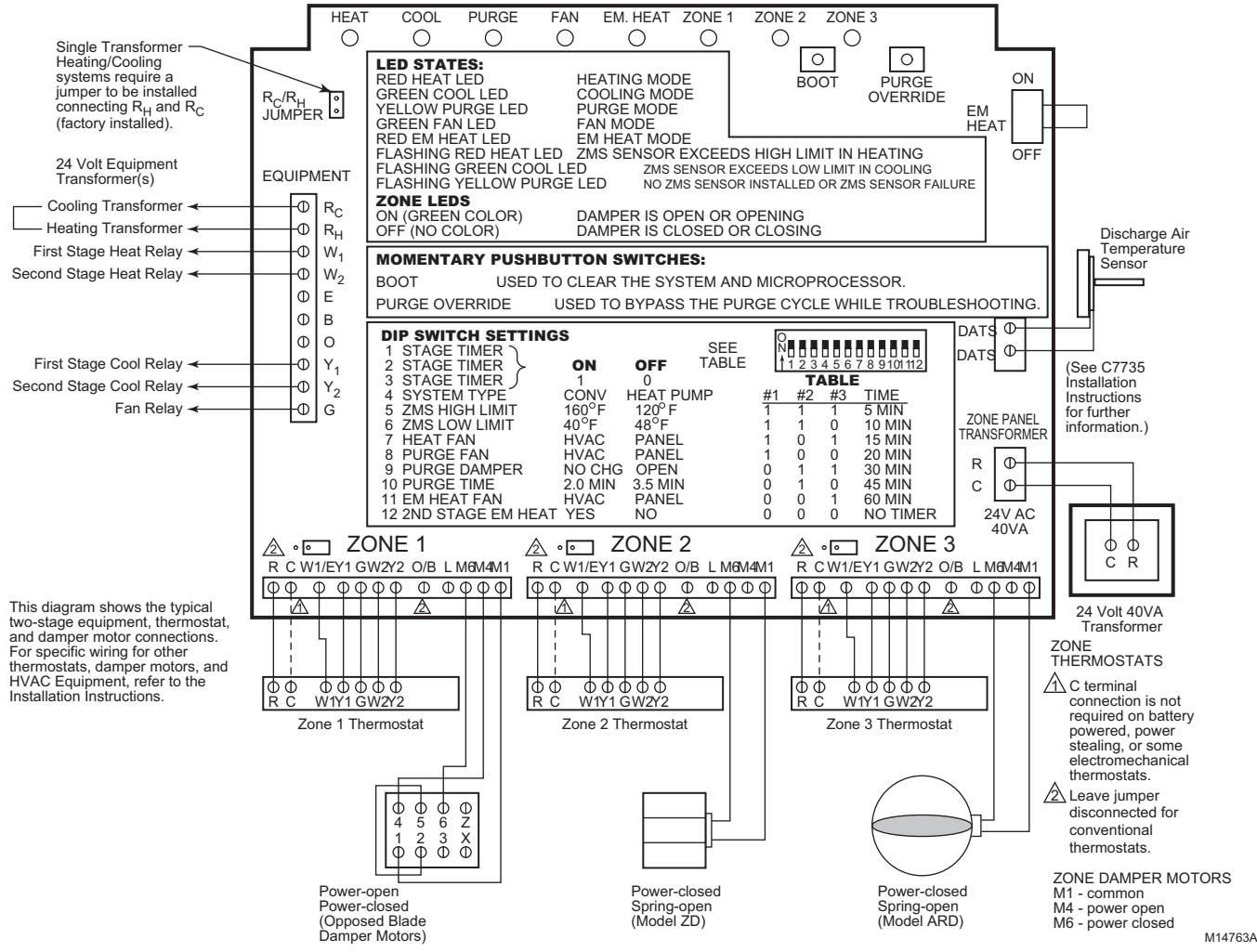

Fig. 13. EMM-3U System wiring diagram.

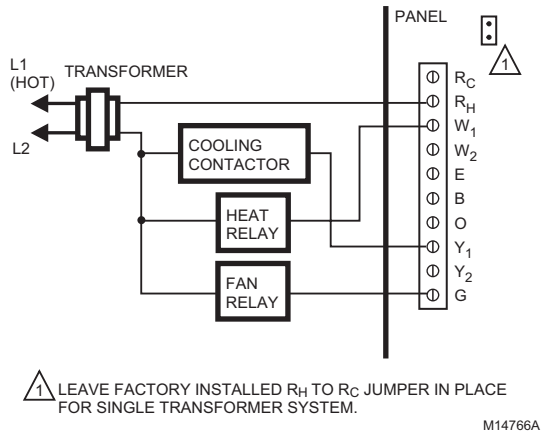

Fig. 14. Conventional single-stage single transformer system wiring diagram.

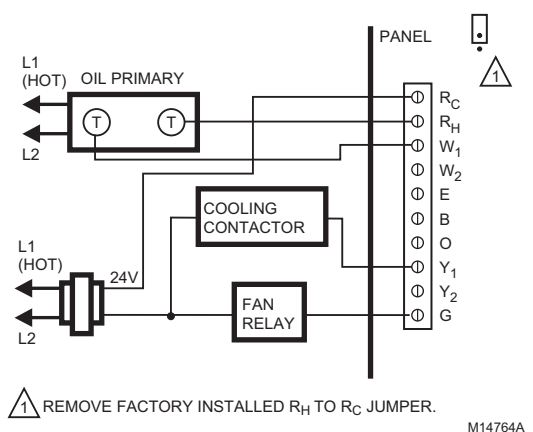

Fig. 15. EMM-3U oil heating wiring diagram.

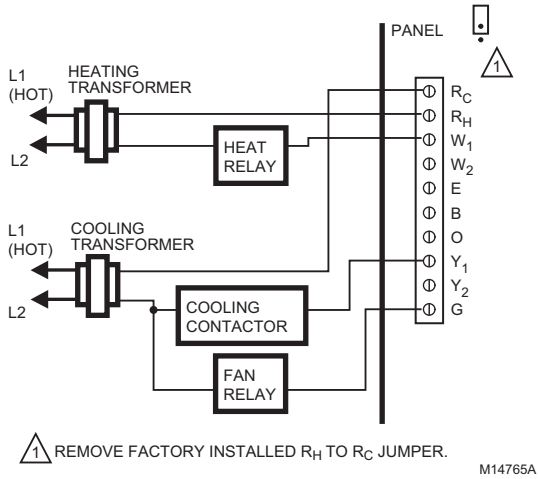

Fig. 16. Two-transformer system wiring diagram.

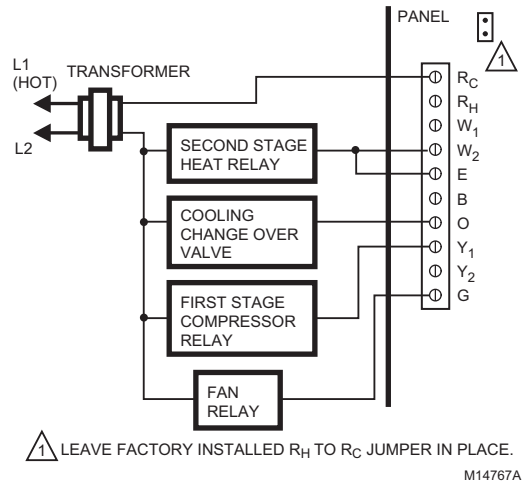

Fig. 18. Single-stage heat pump with auxiliary heat wiring diagram.

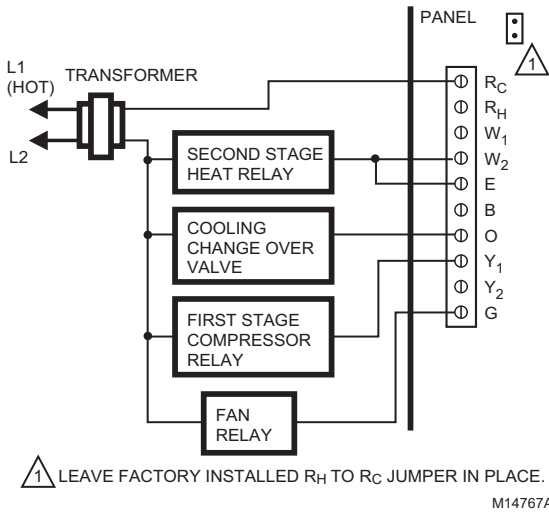

Fig. 17. Single-stage heat pump with separate auxiliary and emergency heat wiring diagram.

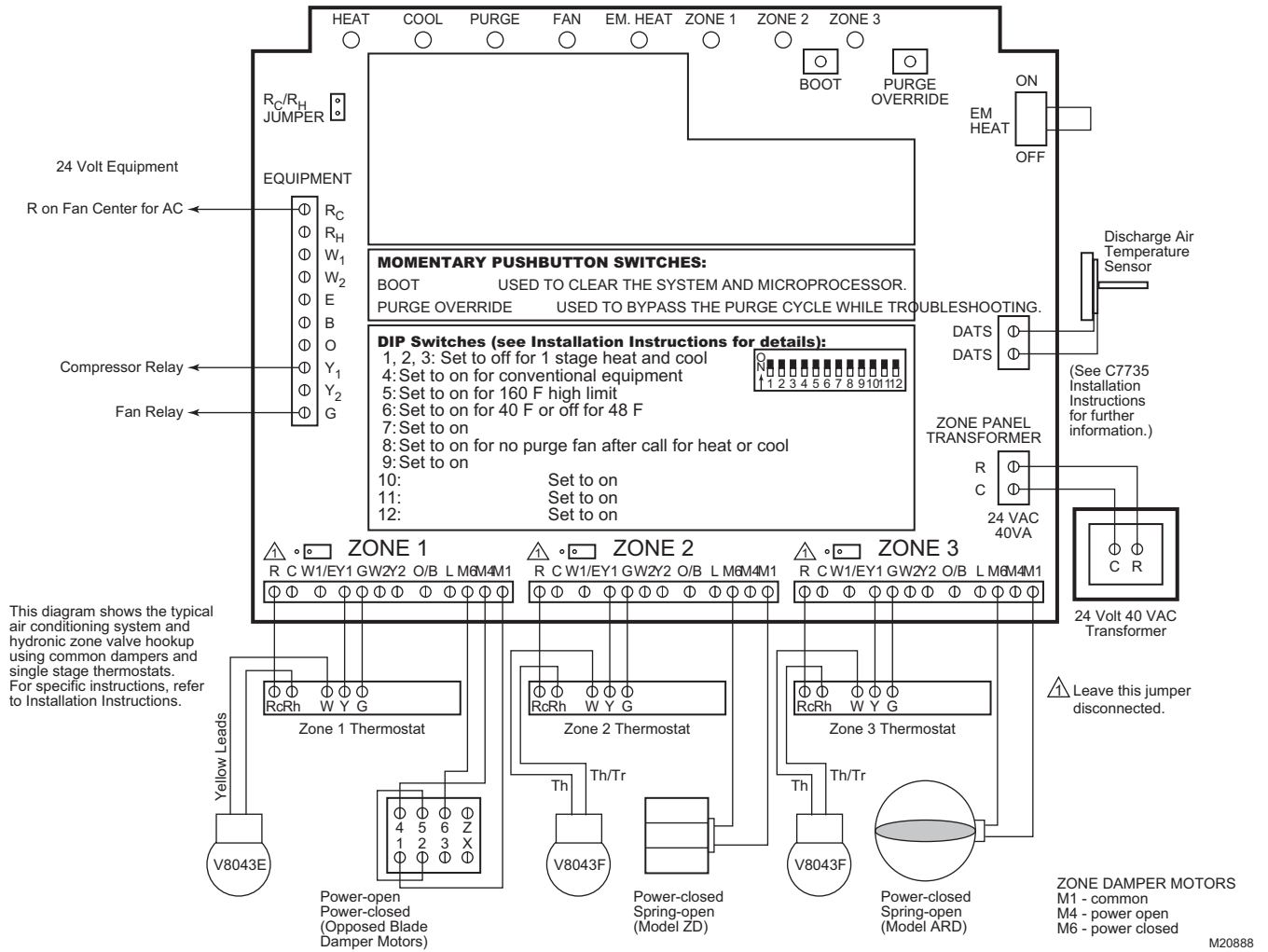

Fig. 19. EMM-3U with Air Conditioning Zoned with Dampers and Hydronic Heat Using V8043 Zone Valves.

## STARTUP AND CHECKOUT

After the installation is complete, verify correct operation:

1. Place the Em Ht switch in the Off (down) position.
2. Verify that DIP switches are set correctly.
3. Turn on power to the EMM-3U Panel and set the thermostats so no zones are calling.
  - a. EMM-3U enters the Purge Mode, opening all dampers and operating the fan for two or three and one-half minutes (configurable). In Purge, damper LEDs are green to indicate the dampers are open.

NOTE: If a Discharge Air Temperature Sensor is not connected to the panel, the purge LED flashes in all modes other than Purge.

- b. Press the Purge Override button on the panel to exit the Purge mode early.
4. Set the zone one thermostat to heat and raise the setpoint to call for heat.

5. Verify that the heat LED is red and the zone one damper remains green while the other damper LEDs turn off.
6. Raise zone two setpoint to call for heat. Lower zone one setpoint to stop the call for heat to that zone.
7. Verify that zone one LED turns off and zone two LED turns green.
8. Repeat for zones two and three.
9. Alternately, set the System switch to Cool, and lower the setpoint to call for cooling.
10. Verify that the green cool LED illuminates.

## OPERATION

### Identifying DIP Switches

This panel has one bank of 12 DIP switches numbered starting with 1 on the left. The switches are shipped in the On (Up) position. See Fig. 13 and Tables 4 and 5.

## Sequence of Operation

- When there is no call for heat, cool, or fan, the EMM-3U is in the Idle mode. No system LEDs are illuminated and the damper LEDs are green to indicate open.
- On a call for heat, cool, or fan, the calling zone damper stays open, and the other zone dampers close:
  - Panel energizes the HVAC equipment and conditioned air is delivered to the calling zone.
  - Heat LED (red), cool LED (green), or fan LED (green) illuminates to indicate equipment operation.
  - Fan LED illuminates only during a call for circulation; it does not illuminate during a call for heat or cool.
- When the call is satisfied, the system enters the Purge mode. After Purge, all dampers return to the Open position
- Any zone thermostat can call for heating or cooling. If there are co-existing calls for heat and cool, the panel accepts the first call.
- Once a call is satisfied, or a maximum of 20 minutes has elapsed, the panel switches to allow the opposite call after completing Purge mode.

## Purge Mode

- At the end of every call for heat or cool, the panel enters a Purge mode that holds open the calling zone damper for two minutes (default) or three and one-half minutes. During this time, the panel or the HVAC equipment can be configured to operate the fan.
- The Purge LED lights to signal that the system is in the Purge mode. Pressing the purge override button overrides the Purge mode.
- Unless there is a new call for heat or cool during the Purge mode, all dampers are moved to the Open position at the end of Purge.
- The panel can be configured to open all dampers during purge mode. See Table 4 to configure the Purge mode using DIP switches 8, 9 and 10.

## Individual Zone Fan Control

- The fan switch of each thermostat controls the fan operation for that zone.
- When the Fan switch is in the On position, the fan is energized, and dampers close to zones where the Fan switch is in Auto position.
- During a call for heat or cool at this time, the circulation mode ceases, and the heat or cool call is honored.
- When the zone calling is satisfied, the circulation call resumes.

## Single- and Multi-Stage Operation

The panel can control up to two stages of heat and cool:

- First stage is energized by the thermostat
- Second stage of heating or cooling can be energized by the thermostat or timer.

### Single-Stage

Select a single stage thermostat, see Table 1. Set DIP switches 1, 2, and 3 to Off to disable the stage timer.

### Multi-Stage

#### THERMOSTAT-CONTROLLED STAGES

- Select a multi-stage thermostat, see Table 1, that energizes W2 and Y2 for second stage of heat and cool.

- Configure DIP switches 1, 2 and 3 to Off to disable the stage timer.

## Timer Controlled Stages

- The panel stage timer energizes the second stage of heat or cool after the first stage has been calling for a specified amount of time.
- Second stage remains energized until the call for heat or cool is satisfied.
- See Table 5 for stage timer configuration.

## Heat Pump Operation

The panel can control single or two stage heat pumps with or without auxiliary heat:

- Set DIP switch 4 to Off for heat pump control. This energizes the Y1 on a call for first stage heat or cool.
- Set DIP switch 7 to Off to engage the fan with a call for heat.

## Thermostat Controlled Stages

- Select a thermostat from Table 1. Configure DIP switches 1,2, and 3 to off to disable the stage timer.
  - When thermostat calls for first stage, panel energizes Y1, G and the correct reversing valve terminal.
  - When the thermostat calls for second stage heat on W2, the panel energizes the equipment W2 terminal.
- Recommended heat pump thermostats can switch the panel to emergency heat:
  - In this mode, Y1 equipment terminal is disabled and E is energized on a call for heat.
  - If the same source of heat is used for emergency heat and auxiliary heat, W2 and E equipment terminals must be jumpered.
- Emergency heat can be energized by the Em Heat switch on the panel.
- If the equipment is a two-stage heat pump, W2 and Y2 equipment terminals must be jumpered and wired to the second stage compressor contactor.
- If the equipment is a two-stage heat pump with auxiliary heat, select the TZ-4 TotalZone™ panel.

## Timer Controlled Stages

If single-stage thermostats are used, the EMM-3U can energize second stage using stage time:

- The timer can be set to engage second stage heat or cool after the first stage has been calling for the specified length of time.
- See Table 5 for DIP switch configuration.

## Thermostat Operation

### Conventional Thermostats

Conventional (R,W,Y,G) heat/cool thermostats can be used with the EMM-3U to control single or multi-stage gas, electric, or oil systems and heat pumps with or without auxiliary heat.

- For two stage heat or cool equipment, configure the stage timer with DIP switches 1, 2 and 3. See Table 5. This enables the panel to engage second stage after stage one has been calling for the specified length of time.

- Heat pumps can be controlled by conventional thermostats because the EMM-3U controls the reversing valve based on whether the panel is in heat or cool.
  - It controls auxiliary heat through the stage timer.
  - For heat pump applications, set DIP switch 4 to Off.
- In all cases, when a conventional thermostat is used, the O/B thermostat type jumper located next to each thermostat connection must remain disconnected.

### Heat Pump Thermostats

Heat pump thermostats that have a single Y terminal for first stage heat and cool and those with separate Y1 and W1 can be used with the EMM-3U. Thermostats of either type can be used on any zone. Set DIP switch 4 to Off for heat pump control.

#### HEAT PUMP THERMOSTATS WITH SINGLE Y OUTPUT

Thermostats with a single Y wire for first stage heat and cool can be connected to the EMM-3U. O/B thermostat type jumpers must be set correctly:

- If the thermostat uses O for changeover, connect it to the O/B thermostat terminal on the panel and connect the O/B jumper on the panel. (There is one jumper for each zone.)
- If B is used, leave the jumper disconnected.

#### HEAT PUMP THERMOSTATS WITH SEPARATE Y1 AND W1 TERMINALS

- Heat pump thermostats with separate Y1 and W2 terminals for first stage can be used to control a heat pump.
- On these installations, it is not necessary to connect O or B from the thermostat.
- Leave the O/B thermostat type jumper disconnected.

### Emergency Heat Control

NOTE: Emergency heat is defined as using an auxiliary heat source without using the heat pump. When the Em Heat switch is in the Em Ht position, the heat pump is locked out and calls for heat are sent to the E equipment terminal.

- A recommended heat pump thermostat (see Table 1) can also switch the board to the emergency heat mode. When one or more thermostats is in emergency heat, the board locks out the heat pump.
- When the same source of heat is used for auxiliary heat and emergency heat, the W2 and E equipment terminals are jumpered together. Set DIP switch 12 to the Off position.
- When a different source of heat is used for Auxiliary Heat and Emergency Heat, Auxiliary Heat is wired to W2 and Emergency Heat is wired to E. Set DIP switch 12 to On. When the EMM3-U is then set to Emergency heat, it first engages equipment terminal E on a call for heat and the second stage of emergency heat is then W2.

### Multi-Stage Thermostats

Use multi-stage thermostats to control up to two stages of heat or cool with the Y2 and W2 thermostat terminals on the panel.

### Manual and Automatic Changeover Thermostats

Manual or automatic changeover thermostats can be used.

- The panel determines the call for heat or cool based on which was called for first.
- Subsequent calls for heat or cool are honored when the initial call is satisfied, or 20 minutes has elapsed.

### Rebooting the Microprocessor

To reset the panel, press and release the Boot button. The system reboots and enters the Purge mode.

### Discharge Air Temperature Sensor

The C7735A1000 Discharge Air Temperature Sensor is a supply-duct-mounted temperature probe used to control capacity and prevent high limit or coil icing.

- The sensor attaches to the two DATS terminals on the panel.
- When a high or low limit is reached, the panel shuts off the equipment and keeps the fan operating for 2-1/2 minutes.
- After this time, it re-energizes the equipment after the discharge air temperature recovers by ten degrees.
- When the DATS exceeds the high or low limit, the Heat (red) or Cool (green) LED flashes.
- Set the temperature to 120°F for heat pump systems or 160°F for fossil fuel. The low limit can be set to 40°F or 48°F.

See Table 4 to configure high and low limit using DIP switches 5 and 6.

#### IMPORTANT

*Be sure the Discharge Air Temperature Sensor wiring does not run parallel with line voltage wiring unless more than 12 inches of separation exists or shielded cable is used.*

NOTE: The yellow purge LED flashes in all modes other than purge when there is a DATS failure, a wiring problem, or when no DATS is connected to the panel.

The zone control panel will continue to operate correctly when the purge LED is flashing but without the high and low limit protection.

### Circuit Breaker Protection

A built-in thermal circuit breaker protects the panel against shorts in the thermostat and damper wiring:

- When the circuit breaker is tripped, none of the LEDs illuminate and the yellow rectangular component located left of the R and C terminals is hot when touched.
- Remove power to the panel for at least five minutes to allow the breaker to cool and reset.
- To eliminate the short, verify damper and thermostat wiring.

### Fan On In Heat

The system blower can be set to come on with a call for heat as required for hydro-air or electric heat systems:

- Setting DIP switch 7 to Off configures the blower to engage with a call for heat.

**Table 4. DIP Switch Settings and Functions.**

DIP Switch	Function	On (Default)	Off
1	Stage Timer	See Table 5.	
2	Stage Timer	See Table 5.	
3	Stage Timer	See Table 5.	
4	System Type	Conventional	Heat Pump
5	DATS High Limit	160	120
6	DATS Low Limit	40	48
7	Heat Fan	HVAC controls fan in heat	Panel engages fan in heat
8	Purge Fan	Purge Fan controlled by HVAC	Panel engages Purge Fan.
9	Purge Damper	Purges into last zone calling	Purges into all zones
10	Purge Time	Two minutes	3-1/2 minutes
11	EM Heat Fan	HVAC controls fan in EM heat	Panel engages fan with heat
12	2 <sup>nd</sup> Stage Em Heat	Yes	No

**Table 5. Stage Timer Configuration.**

Time (Minutes)	DIP Switch 1	DIP Switch 2	DIP Switch 3
5	On	On	On
10	On	On	Off
15	On	Off	On
20	On	Off	Off
30	Off	On	On
45	Off	On	Off
60	Off	Off	On
No Timer	Off	Off	Off

# TROUBLESHOOTING

The primary diagnostic tools are the System and Zone damper status LEDs and BOOT and PURGE OVERRIDE buttons. See Fig. 20 and 21 for troubleshooting flowcharts.

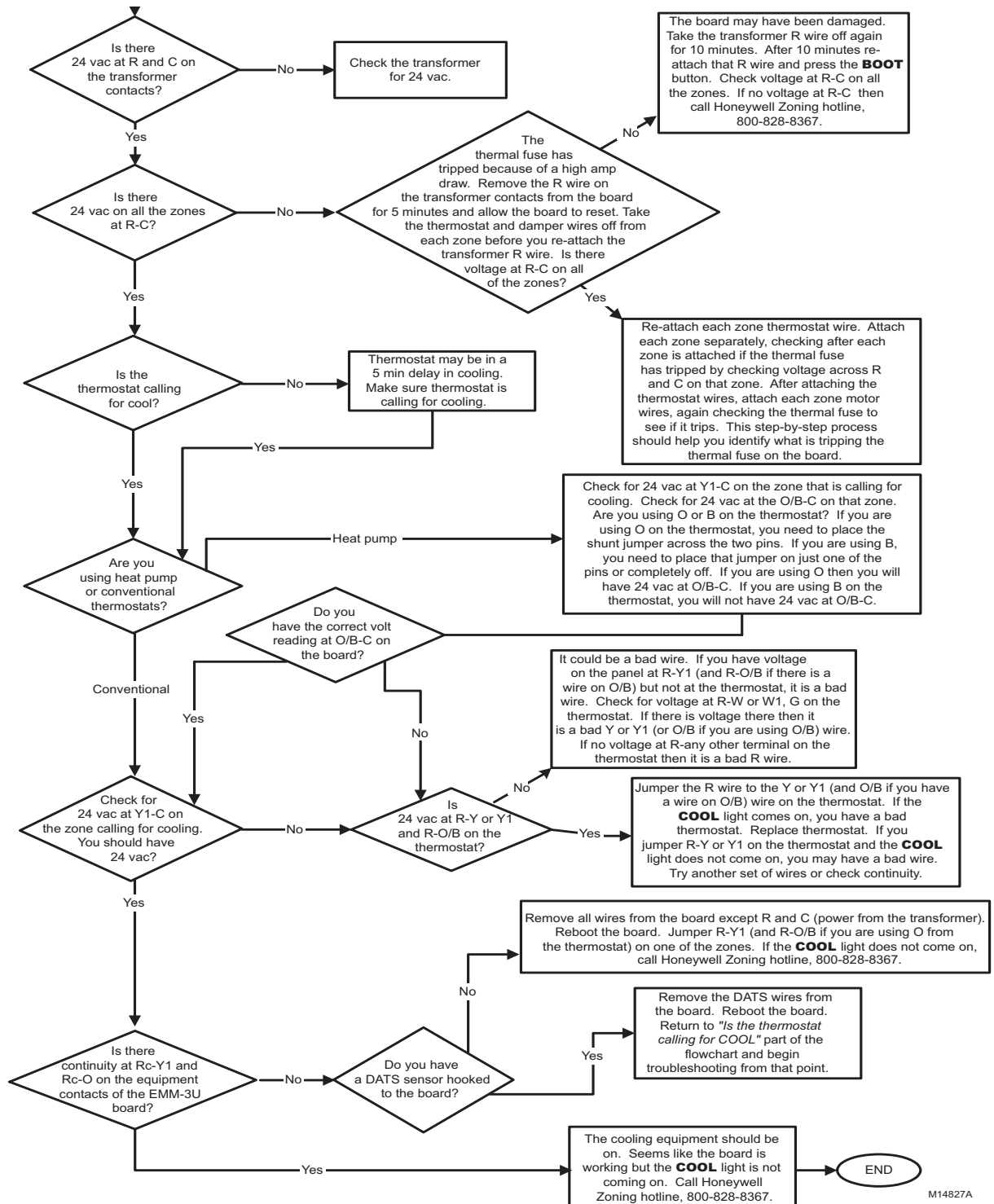
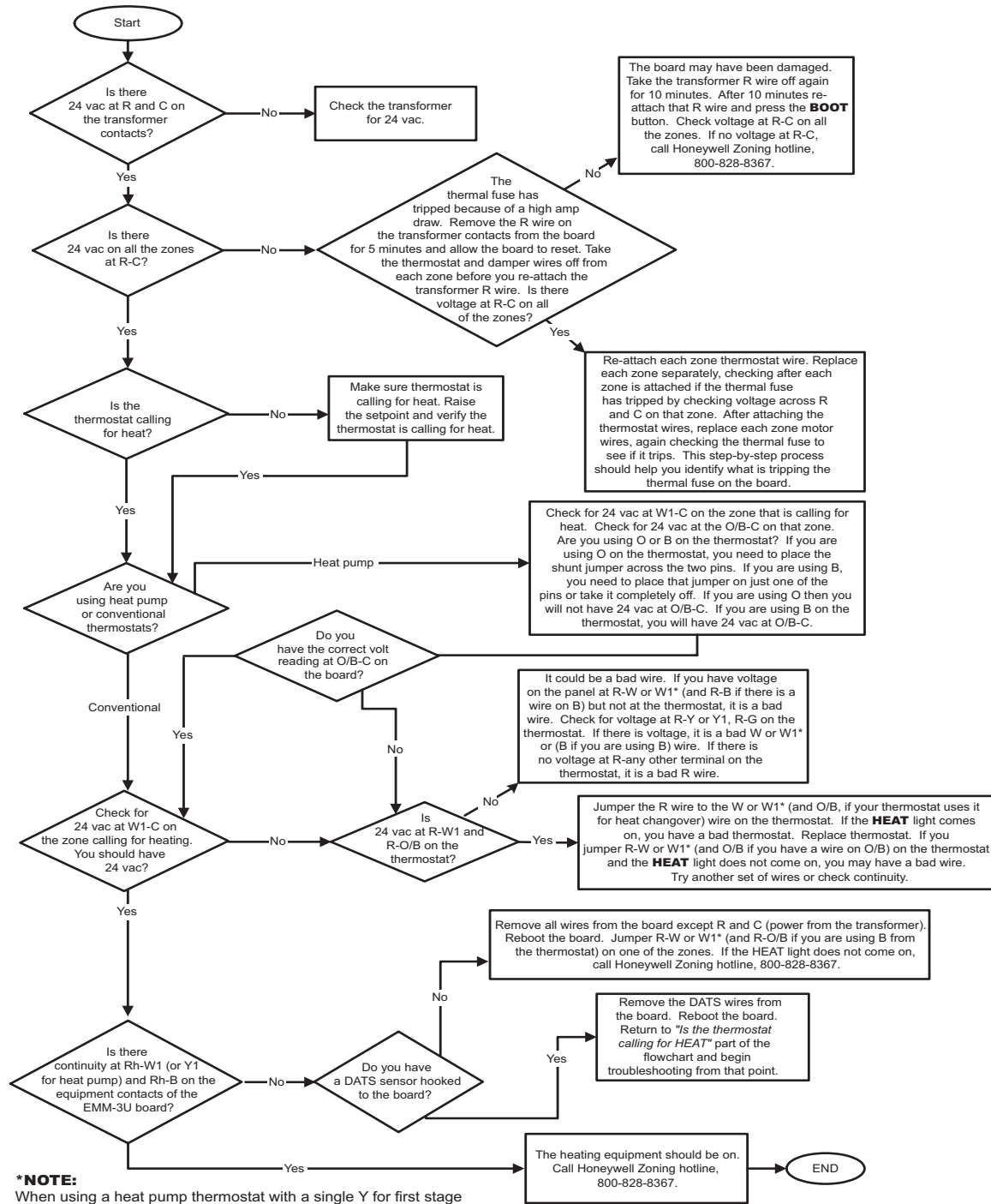

Fig. 20. Thermostat is calling for cooling but the Cool LED is not turning green to show a cool call.



M14828A

Fig. 21. Thermostat is calling for heating but the Heat LED is not turning red to show a heat call.



Automation and Control Solutions

Honeywell  
1985 Douglas Drive North  
Golden Valley, MN 55422

Honeywell Limited-Honeywell Limitée  
35 Dynamic Drive  
Scarborough, Ontario  
M1V 4Z9